

splash display



Box Display System

Raymarine®



Box Display™ from Splash, a versatile way to promote your brand, a lightweight, easy to mail solution. Used all over the world this system is revolutionary in-store.

Each carton is offset printed on four sides and flat packed in a card skillet, ready to send.

A selection of fittings can be supplied to allow it to be hung or freestanding.

Raymarine®



Raymarine

Raymarine

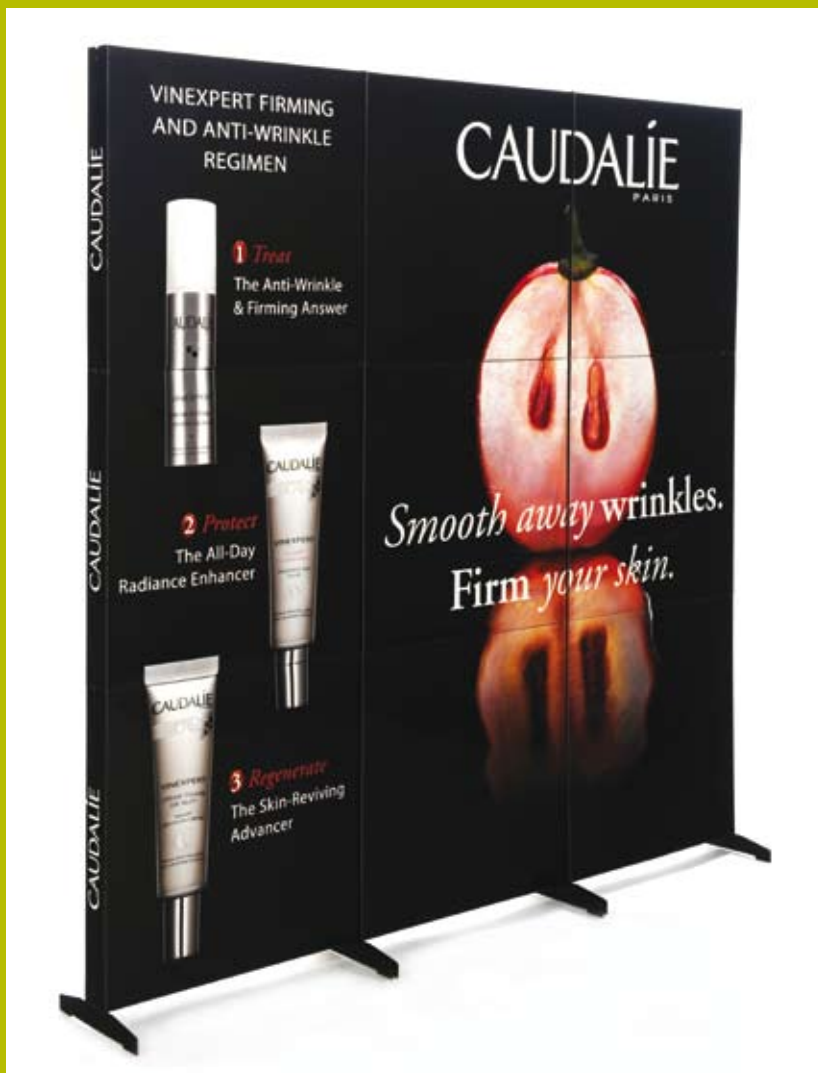

Easy to Assemble

No tools required. Snap together box construction with special connectors allow the Box Display™ to be assembled in minutes.

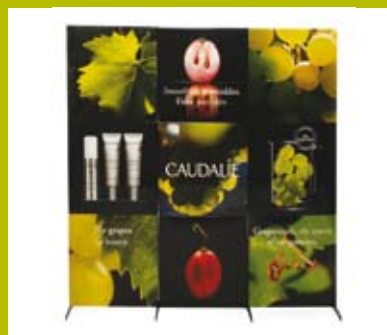

Versatile

The modular design of the system can be modified to create floor towers, mobiles and walls. All the connectors are supplied, based upon the Box Display™ system that you choose.

Quality Graphics

High quality printing with rich images, crisp logos and clear messages grab attention in high traffic areas and help to generate sales. Special high gloss or matte finishes available.

Value

Use existing adverts, artwork and logos to create your Box Display™. You will not have to pay for the cost of structure design, tool or die cutting costs.



Customisation

Brochure holders, poster holders and product can be added to your Box Display™ using shelves or hooks. Just ask – we will find a solution for your needs.



50cm x 180cm



50cm x 180cm

50cm x 130cm

50cm x 110cm



50cm x 150cm

Free standing towers are available with feet or wide format bases allowing stability for taller configurations such as walls and arches.



200cm x 180cm



150cm x 50cm

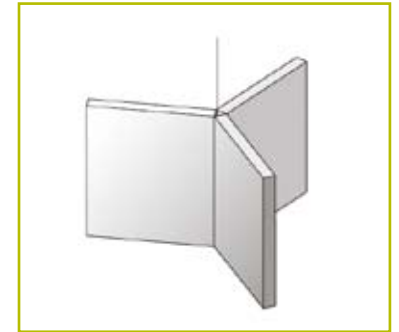

210cm x 140cm

280cm x 230cm

Build Walls – Create Impact with 9, 12 and even 16 panel walls using the special connectors.

Special connectors allow the units to be hung from the ceiling, in either horizontal or star configurations as shown here.

splash display



Splash Display Limited
New Solent House
1 Ashlett Road Fawley
Southampton Hampshire
SO45 1DS

www.splashdisplay.com info@splashdisplay.com
Telephone: 0845 226 1936 Fax: 0845 226 1937